

Dosimetry for Tangential Chest Wall Irradiation¹

Peter Fessenden, Ph.D., Bernice B. Palos, B.A.,
and Clarence J. Karzmark, Ph.D.

The skin-sparing effect of megavoltage photons is lost to a varying extent when tangential beams are used to irradiate the chest wall. The skin dose for this technique, with and without a bolus, was investigated for 4- and 6-MV photons using film, thermoluminescent dosimeters, and an ionization chamber. Metal/tissue interface effects were observed when a flexible brass fabric material was used as a bolus.

INDEX TERMS: Therapeutic radiology, dosimetry • Thorax, therapeutic radiology • Treatment planning

Radiology 128:485-489, August 1978

WHEN THE chest wall is treated with 180° opposed tangential fields, the dose distribution is routinely calculated in the central axis plane only and does not account for the bolus. The isodose curves are not extrapolated to the surface contour because of insufficient knowledge of the superficial dose from tangential fields. We have measured the dose at or near the skin at 4 and 6 MV using thermoluminescent dosimeters (TLD), film, and an ion chamber. In most cases the chest wall is treated with a Varian Clinac 4, and our most extensive dosimetry was done at 4 MV. We used a cylindrical water phantom 26.5 cm in diameter to approximate the chest-wall curvature of a large patient.

TREATMENT PLANS

The calculated treatment plans are shown in Figure 1, in which the isodose values represent the dose to the chest wall in this essentially source-to-skin-distance (SSD) technique. The accelerator monitor units are set such that if a rectangular block of tissue were present, the point of maximum buildup D_M on each side would receive 50 rads from the beam incident on that side; thus in actual practice (no block of tissue present) the planned rad values in the phantom would be numerically equal to the isodose values shown in the figure. No attempt was made to calculate dose closer to the surface because of the complications introduced by the bolus,² obliquity, exit dose, and interfaces. At 6 MV, for example, the 80% isodose line (80 rads delivered under these conditions) would typically be brought to the 5,000-rad level at the completion of treatment. This would consist of two opposed beams, each of which would deliver (2,500 rads) $(100/80) = 3,125$ rads to the hypothetical D_M on that side. The bolus would be used for $\frac{3}{5}$ of the treatment, although treatment planning does not account for the 4-6% attenuation in the bolus.

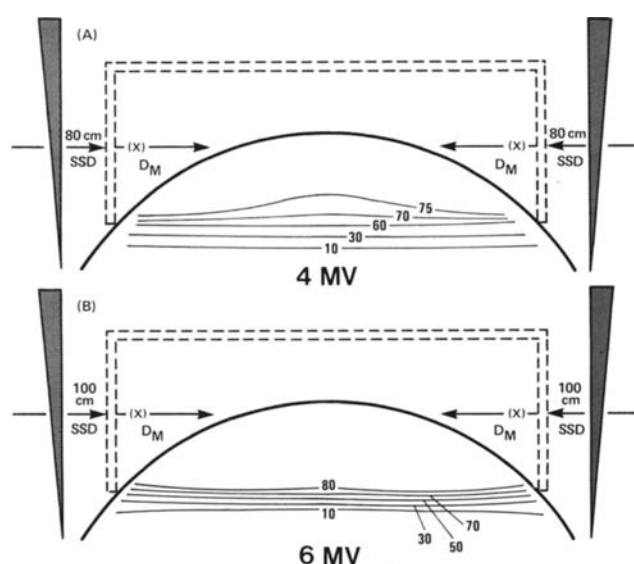

Fig. 1. A and B. Calculated treatment plans and schematic diagram of the setup for irradiation of a chest wall with a radius of curvature of 13.3 cm using opposed tangential fields and 4-MV (A) and 6-MV x rays (B). Fields measuring 7 cm (in the plane of the paper) by 19 cm (perpendicular to the plane of the paper) and 45° wedges were used for both cases. The small xs labeled D_M indicate where the points of maximum buildup for the respective single fields would be if a rectangular block of tissue were present. The setup bridge (removed during treatment) is represented by the dashed line. The bolus is not accounted for. (See text for explanation of isodose values.)

(Attenuation is 2-5% for the thinner bolus used at 4 MV.)

DOSIMETRY MEASUREMENTS

There is considerable skin sparing with either 4- or 6-MV x rays striking tissue-equivalent material perpendicularly.

¹ From the Department of Radiology, Stanford University School of Medicine, Stanford, Calif. Accepted for publication in July 1977.

Presented in part at the Work In Progress: Therapy session of the Fifty-ninth Scientific Assembly and Annual Meeting of the Radiological Society of North America, Chicago, Ill., Nov. 25-30, 1973.

This work was supported by research grant CA-05838 and (for P.F.) by training grant CA-05008 from the National Cancer Institute, NIH.

² Four layers of a brass fabric, each having an average areal density of 0.25 g/cm², are used as the bolus for 6 MV; three layers are used for 4 MV. This bolus conveniently conforms to the body contours, eliminating air spaces between the bolus and the skin surface. The material is available under the name "gold metal fabric" from Whiting and Davis, Plainville, Mass.

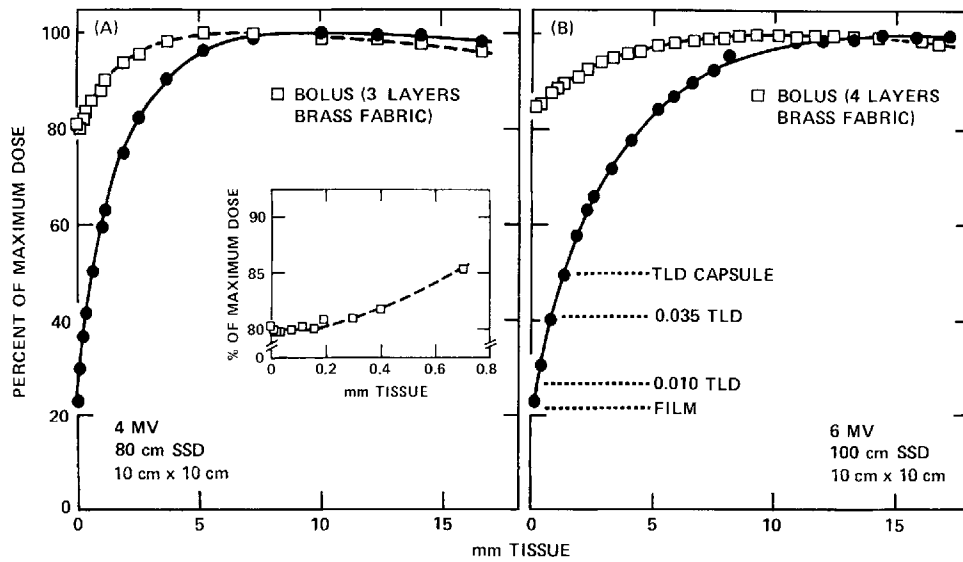

Fig. 2. A and B. Buildup curves for 4-MV (A) and 6-MV x rays (B) with the central axis perpendicular to a thin parallel-plate ionization chamber covered by various thicknesses of polystyrene and/or a bolus. The chamber is built into the surface of a tissue-equivalent phantom, and all four curves are normalized to their local maxima. The very slight dip near the surface in the 4-MV curve (obtained with a brass fabric bolus) is due to interface effects (1, 2). This region is shown magnified in the insert in Figure 2, A. When similar data were determined for the lead bolus (0.5 mm for 4 MV, 0.75 mm for 6 MV), the dip was more pronounced and was present at both energies. Each of the four positions indicated on the lower curve of Figure 2, B represents one of the four types of dosimeters described in the text.

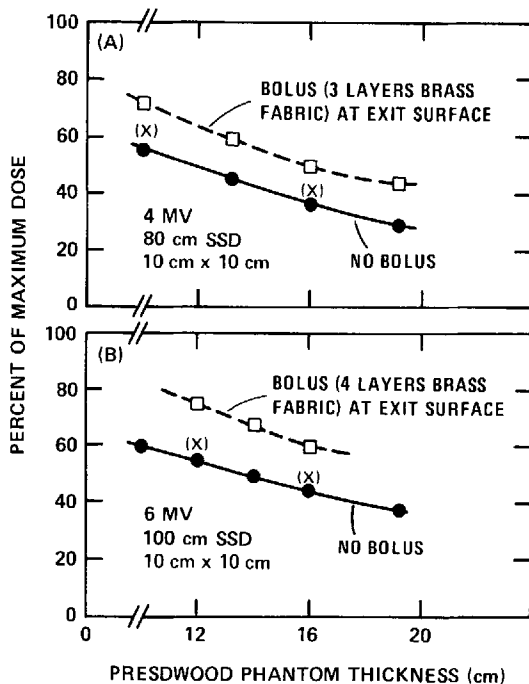

Fig. 3. A and B. Exit doses for 4-MV (A) and 6-MV beams (B) striking the surface perpendicularly. The points denoted by the xs in parentheses represent full tissue backscatter material at the exit surface.

This is illustrated in Figure 2, which shows the result of dose buildup measurements for both bolused and unbolused configurations, using a thin parallel-plate ionization chamber and polystyrene disks of various thicknesses and 10 cm in diameter. The 1-cm ion chamber had a 1-mm-

thick sensitive volume with a 0.025-mm Mylar entrance window. At each depth of overlying absorber, measurements were made with positive and negative polarizing voltages and the results averaged. Averaging is particularly important at shallow depths; for example, the + and - readings typically differ by more than 20% at 0.5 mm but only 1% at 1 cm. Each curve was normalized to its individual maximum, and the depths were corrected to tissue on the basis of electron density.

When a dosimeter of finite thickness is used to measure surface dose,³ the results may be misleading because of buildup within the instrument itself. In this study we used a single Kodak RP/V2 X-Omat therapy verification film (in its pack), a lithium fluoride (LiF) ribbon measuring 3.2 mm (1/8 in.) long by 3.2 mm wide by 0.25 mm (0.010 in.) thick,⁴ an LiF ribbon of similar dimensions but 0.9 mm (0.035 in.) thick,⁴ and a throwaway capsule of TLD powder 4 mm in diameter⁵ placed on the surface of a flat phantom struck by a perpendicular beam of 6-MV x rays. It is apparent that of the four, the most accurate assessment of surface dose will be obtained with the film. However, for contoured surfaces (including patients), film is usually inconvenient and the thinner TLD ribbons are more useful. Orton and Seibert (3) have reminded us that the epidermal layer of skin is about 0.05 mm thick and the underlying dermal layer

³ Surface dose here means the dose measured by placing a thin dosimeter (0.07 g/cm²) on the patient's skin or the surface of the phantom. Skin dose refers to the dose measured at various depths up to approximately 1 mm and includes surface dose.

⁴ TLD-100 high-sensitivity ribbon, Harshaw Chemical Co., Solon, Ohio.

⁵ Radiation Detection Co., Mountain View, Calif.

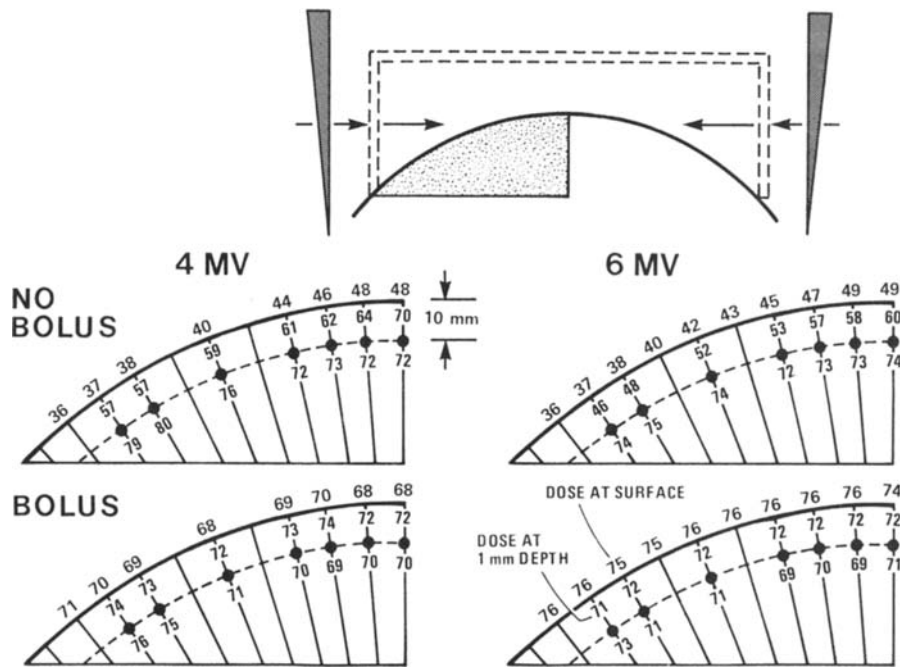

Fig. 4. Skin doses measured with the chest wall phantom for 4-MV and 6-MV x rays both with and without the bolus. The dose was 50 rads delivered from the right to the D_M on the right and 50 rads from the left to the D_M on the left. As before, a 7×19 -cm field (10-cm equivalent square) was used. The radial lines are 1 cm apart at the surface, starting from the midline at the right; the numbers correspond to doses at the surface, 1 mm, and 10 mm (dashed line). Only one side of the symmetrical distribution is shown, indicated by the shaded portion of the schematic drawing at the upper right.

is roughly 1 mm thick. Thus the 0.9-mm ribbon and the capsule are not suitable for determining the dose in the dermal layer (Fig. 2, B).

The exit dose is a significant component of the dose near the surface in the opposed tangential field treatment. Measurements of exit dose using film and a 30×30 -cm Presdwood⁶ phantom of variable thickness were made in order to assess this phenomenon and to demonstrate the additional importance of interface effects when a bolus having an electron density different from that of tissue is used. The film was placed against the exit side of the phantom, with and without the brass bolus placed distal to the film. Figure 3 shows that the exit dose with no bolus is lower than the dose with full tissue backscatter present and also demonstrates the substantial increase in dose relative to full tissue backscatter when the bolus is present. This increase is an interface effect and would not be expected if a tissue-equivalent bolus were used.

The entering skin dose will be affected significantly by obliquity; the more glancing the beam with respect to the surface, the greater the dose. Jackson (4, 5) has shown that skin sparing may be reduced significantly by obliquity. His "electron range curve" theory can be used to predict the effects of obliquity, particularly for a simple unbolused surface with only an entering beam. However, since the opposed tangential field treatment with fractional bolusing

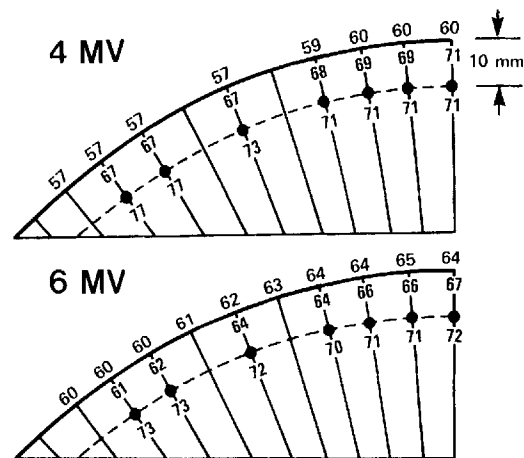

Fig. 5. Dose distributions produced by combining the data of Figure 4, using the bolus $\frac{3}{5}$ of the time.

involves other factors, namely the bolus, the inverse square law, exit dose, and interface effects, skin dose is best determined by direct measurement.

Figures 4 and 5 show skin doses measured for opposed tangential fields (with 45° wedges) using the chest wall phantom, generally with film wrapped tightly around the surface. Some of the surface dose measurements were made during an evaluation of the feasibility of obtaining accurate patient skin surface doses by wrapping 0.25-mm TLD ribbons between two layers of very thin transparent

⁶ Untempered Masonite Presdwood (density $0.96 \text{ g/cm}^3 \pm 3\%$), Masonite Corp.

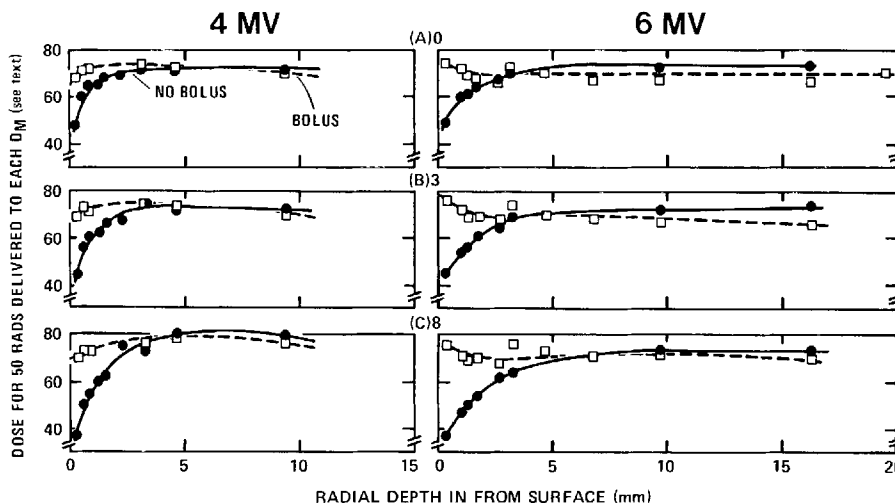

Fig. 6. A-C. Representative buildup curves for 4-MV and 6-MV x rays using opposed tangential fields, shown as a function of depth along a radius of the chest wall phantom at the midline (0) (A), 3 cm along the surface from the midline (3) (B), and 8 cm from the midline (8) (C) (note the suppressed scale on the ordinate). The dashed curves represent measurements taken with the bolus present. Not all data points were obtained in the same series of measurements, and the scatter about the smooth curves indicates the reproducibility of the data.

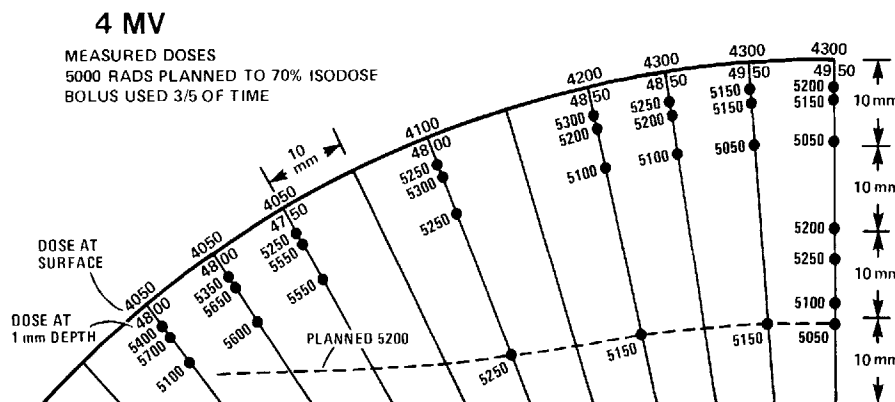

Fig. 7. Actual doses received by the phantom when 5,000 rads of 4-MV x rays at depth (70% isodose line of Fig. 1, A) is delivered. This is the same section of the chest wall shown as a shaded region in Figure 4. Data were derived from film measurements as well as with a Baldwin-Farmer 0.6-cm³ ion chamber immersed in the water phantom. The dashed line is the 5,200-rad isodose line predicted by treatment planning. The surface dose (actually at a depth of 0.3 mm due to the thickness of the film pack) is indicated by the numbers (4,300 to 4,050) along the top of the diagram, while the doses at 1 mm are shown by the numbers just below. The solid circles and the scales in the figure locate the positions of the other dose values.

material.⁷ The dose below the surface was determined by placing several layers of polyethylene over both phantom and film. This increased the diameter of the phantom to slightly over 26.5 cm, and errors of 2% were introduced when the doses were said to be those of the 26.5-cm phantom. However, some cancellation takes place because the errors are of opposite signs for entrance and exit doses, so that no correction was made. The layers of polyethylene (density of 0.92 g/cm³) were corrected to tissue-equivalent thickness. The data without the bolus in Figure 4 show that the dose increases with depth much more rapidly than for perpendicular incidence (Fig. 2). The surface dose for the bolus is lower at 4 MV than at 6 MV,

but buildup in the first millimeter is more rapid for 4 MV than for 6 MV when no bolus is used. Figure 5 compares skin doses resulting from the typical treatment technique of ³/₅ bolused, ²/₅ unbolused. The surface values for 4 MV are slightly less than for 6 MV, which is not true at 1 mm. As indicated by the treatment plans shown in Figure 1, the dose delivered to the D_M of a hypothetical block of tissue could be greater for 4 MV in order to deliver 5,000 rads at depth, which in turn leads to higher skin doses for the 4-MV treatment.

The rapid buildup of dose with depth for opposed tangential fields (measured radially inward from the surface) is shown in more detail in Figure 6. When a bolus is used, the dose reaches a maximum very early, particularly for 6 MV. In fact, at 6 MV (but apparently not at 4 MV) the

⁷ Saran Wrap, 0.03 mm (0.001 in.) thick.

obliquity and metal/tissue interface effects at both entrance and exit enhanced the dose within the first millimeter. Even without the bolus, the maximum dose for both energies is nearly obtained by a depth of about 4 mm. The higher dose at depth for the lateral position at 4 MV is due primarily to the nonlinear inverse square relationship: this is the same phenomenon responsible for higher doses near the surface for any opposed fields at shorter source-to-skin distances (SSDs). This effect is also seen in Figure 4, where the lateral hot spot at 4 MV (80-cm SSD) shows doses about 5% higher than in the corresponding region at 6 MV (100-cm SSD) independent of whether a bolus is used.

The measured 4-MV doses are shown in more detail in Figure 7 and are normalized, in that 5,000 rads are planned to the 70% isodose line of Figure 1, A. The dose distributions could be changed slightly by altering the bolus fraction: for example, reducing the bolus fraction to $\frac{2}{5}$ would lower the surface dose by about 350 rads and the 1-mm dose by about 200 rads. At the same time, some regions would receive approximately 50 rads more; this is directly attributable to the decreased effect of bolus attenuation, since the bolus would be used less.

DISCUSSION

The main purpose of this investigation was to determine how the dose produced by opposed tangential chest wall fields (particularly near the surface) differs from the dose at depth predicted by treatment planning. It is an oversimplification to assume that a uniform dose can be achieved throughout the chest-wall volume, even with a careful choice of bolus fraction. Our measurements, which emphasize the rapid buildup of dose near the surface and the importance of exit dose and interface effects, suggest caution in relating skin sparing (or lack thereof) simply to the absence (or use) of a bolus.

The accuracy of dose measurement within the epidermal layer might be improved by using thin layers of TLD powder (3) or TLD-impregnated Teflon disks (6). The thin TLD ribbons (0.25 mm) have a density of 2.64 and are equivalent to slightly less than 0.7 mm of tissue; over any given region, their average thickness is less than that of the dermal layer. The most serious skin damage occurs when too high a dose is delivered to the dermal region, which for the chest wall has an average thickness a little greater than 1 mm (3). Our experience with the ribbons and film gives us confidence that careful techniques allow megavoltage dose determinations near the surface with 4% or better accuracy. When film or TLD data are obtained with flat phantoms and perpendicularly incident fields, our accuracy is typically better than 3%. However, the necessity for precise location of reference marks and dosimeters on a curved phantom with a tangential radiation

field decreases this accuracy due to errors in reproducibility of setup. The worst situation is on the surface, where buildup changes rapidly with position. In a series of 94 repetitive film measurements and intercomparisons of TLD with film (all surface measurements), the standard error was 5.9%. Important precautions for TLD dosimetry include treating all the ribbons the same with respect to the heating cycle, reproducibility in positioning each ribbon in the ovens, and exposing TLD standards to provide a calibration curve each time the ribbons are evaluated. Before being irradiated, the ribbons are annealed for one hour at 400° C and two hours at 100° C. After irradiation and before being evaluated, they are heated for 10 minutes at 100° C. For each set of film data, it is important to expose enough films to form a calibration curve and to run the calibration films through the processor at the same time as the dosimetry films.

When we compared the dose distributions for 6 MV and 4 MV using the same phantom and setup, we found that they were not too different after the $\frac{3}{5}$ bolus fraction was accounted for. The main differences were a comparably higher lateral dose at 4 MV (probably related to the 80-cm SSD) (Fig. 5) and the manner in which the dose varies within the first millimeter (Fig. 6).

Finally, it must be emphasized that the chest wall phantom is an idealization applicable primarily to patients with mastectomies. Our study emphasizes the importance of assessing skin dose in the individual patient (using the TLD ribbons, for example), particularly for irradiation prior to surgery, if the evaluation of skin dose is to be meaningful.

ACKNOWLEDGMENT: We want to express our appreciation to Patricia Steed for her fruitful discussion, assistance with the drawings, and treatment planning.

Department of Radiology
Room S044
Stanford University School of Medicine
Stanford, Calif. 94305

REFERENCES

1. Dutreix J, Bernard M: Dosimetry at interfaces for high energy x and gamma rays. *Br J Radiol* **39**:205-210, Mar 1966
2. Gibbs FA Jr, Palos B, Goffinet DR: The metal/tissue interface effect in irradiation of the oral cavity. *Radiology* **119**:705-707, Jun 1976
3. Orton CG, Seibert JB: Depth dose in skin for obliquely incident ^{60}Co radiation. *Br J Radiol* **45**:271-275, Apr 1972
4. Jackson W: Surface effects of high-energy x rays at oblique incidence. *Br J Radiol* **44**:109-115, Feb 1971
5. Jackson W: Surface effects of high energy x rays at oblique incidence. Letter to the editor. *Br J Radiol* **45**:315, Apr 1972
6. Mansfield CM, Suntharalingam N: Dose distribution for cobalt 60 tangential irradiation of the breast and chest wall. *Acta Radiol [Ther]* **12**:40-46, Feb 1973